

LIQUID FLOW INDICATOR

APPLICATION

The WPC Indicator is designed for monitoring liquid flow in pipelines of 80 to 125 mm bore. It is provided with an optical indicator and electric contacts for remote flow control. The indicator is suitable for synthetic and mineral oils, water.

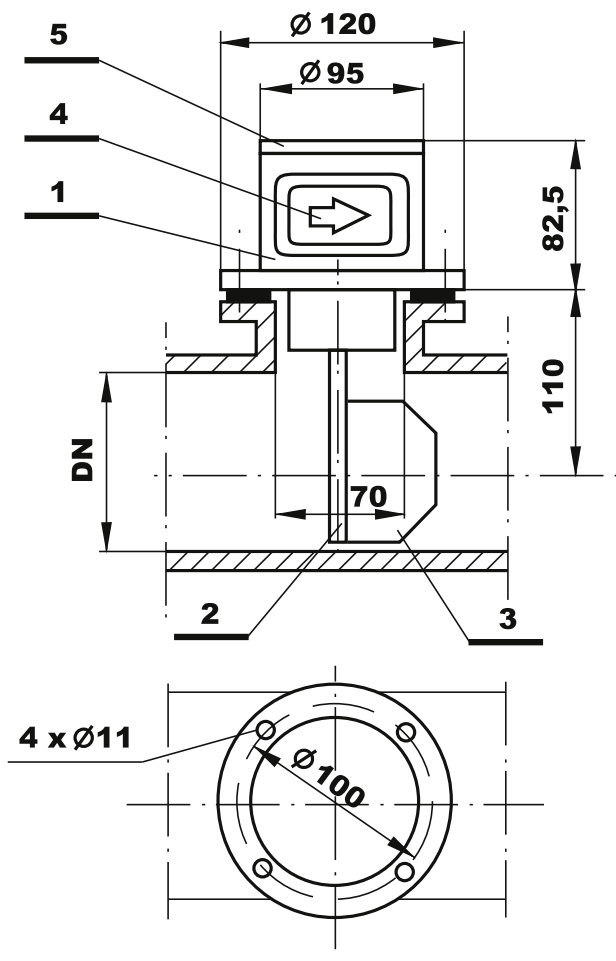



Operating temperature from -30°C to +100°C
 Permissible gauge pressure in pipeline 4000 hPa
 Electric contact rating = 0,8 A; 220 V
 Dimension see drawing
 Weight 1.33 kg
 Climate no limitation
 Maintenance no required

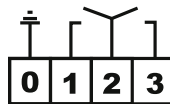

DESIGN AND OPERATION

Case 1 of the WPC indicator made of aluminium alloy, is provided with two separate chambers. One chamber houses a pivoted rod 2 with a magnet and flap 3, actuated by liquid flow in a pipeline. The other chamber houses a pivoted second magnet with an optical indicator 4. The magnets move in synchronism which allows to observe the liquid flow optical indicator through a suitable sight glass. The second magnet actuates contacts of two reed switches to enable remote observation of the flow or no flow conditions. The WPC indicator construction precludes the flowing liquid from crossing the case partition three sizes to suit various pipe line diameters. The indicator is fitted to a flanged stub pipe, welded to the pipeline. Electric cable enters the indicator case through a P 13.5 gland on the case back and is connected to suitable terminal blocs, accessible after removing cover 5.

Note: Orders must include your pipeline diameter DN and flow direction (right or left, right shown above on the drawing).