

MWP-100, MWP-120, MWP-140 MAGNETIC OIL LEVEL INDICATOR

APPLICATION

The MWP indicator is used for indicating liquid level in containers. It is particularly suitable for showing oil level in oil immersed transformer conservators. It is provided with an optical indicator. The indicator can also be applied for synthetic and mineral oils, water.

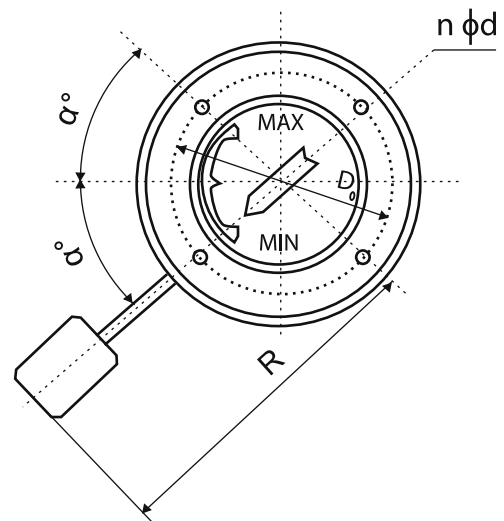

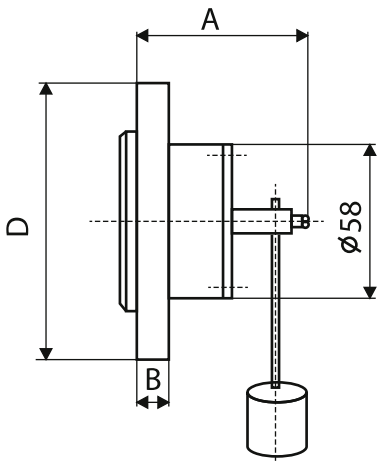

TECHNICAL DATA

		MWP-100	MWP-120	MWP140
Operating temperature	K	243 - 378		
Permissible overpressure in a tank	MPa	0,40		
Weight	kg	0,45	0,55	0,7
Outside diameter	D (mm)	100	120	140
Pitch diameter	Do (mm)	85	105	125
Bore	d (mm)	7	7	7
Number of holes	n	4	4	6
Thickness	B (mm)	10	10	10
Lenght	A (mm)	65	65	65
Lenght of arm	R (mm)	made to order		
Angle of rotation	a (°)	45 ; 60		
Climate	-	no limitations		